

This work is copyright and no part may be reproduced, by any process, nor may any other exclusive right be exercised without the permission of ASSA ABLOY.

Revision	Description	Date
1	AS DRAWN	2018-03-07

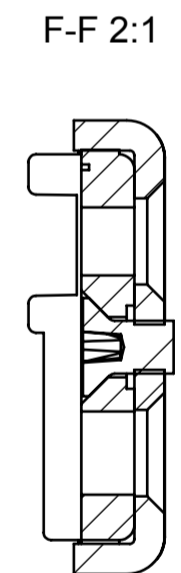
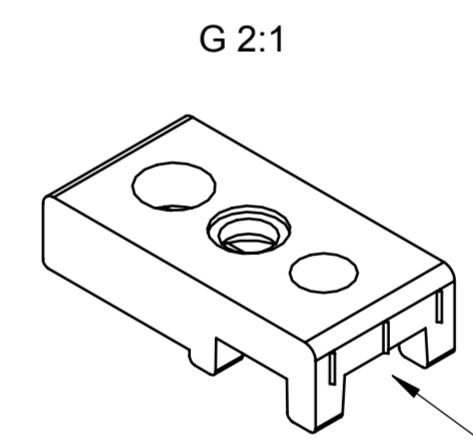
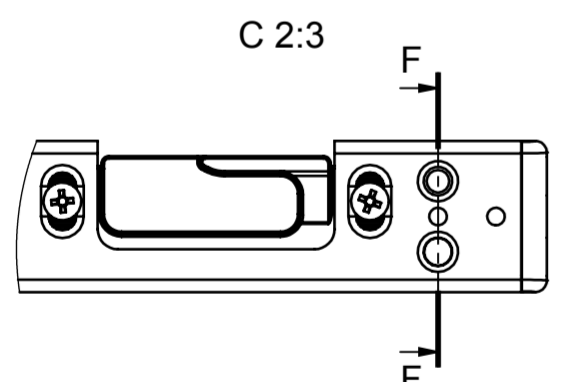
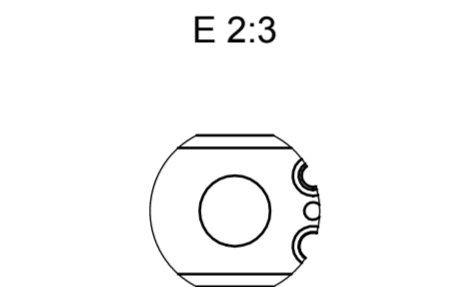
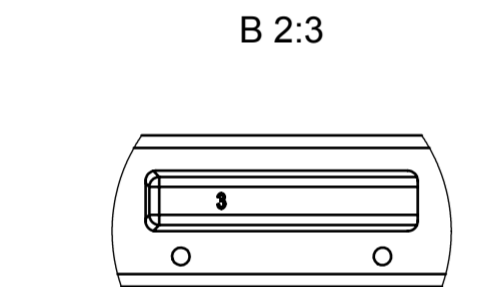
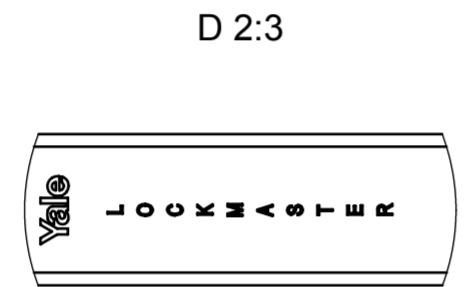
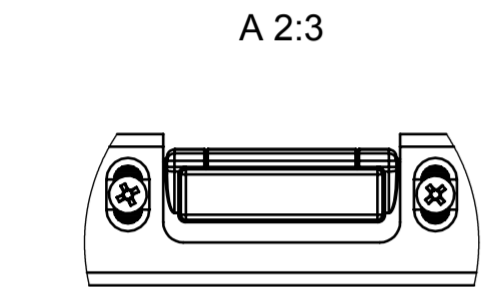
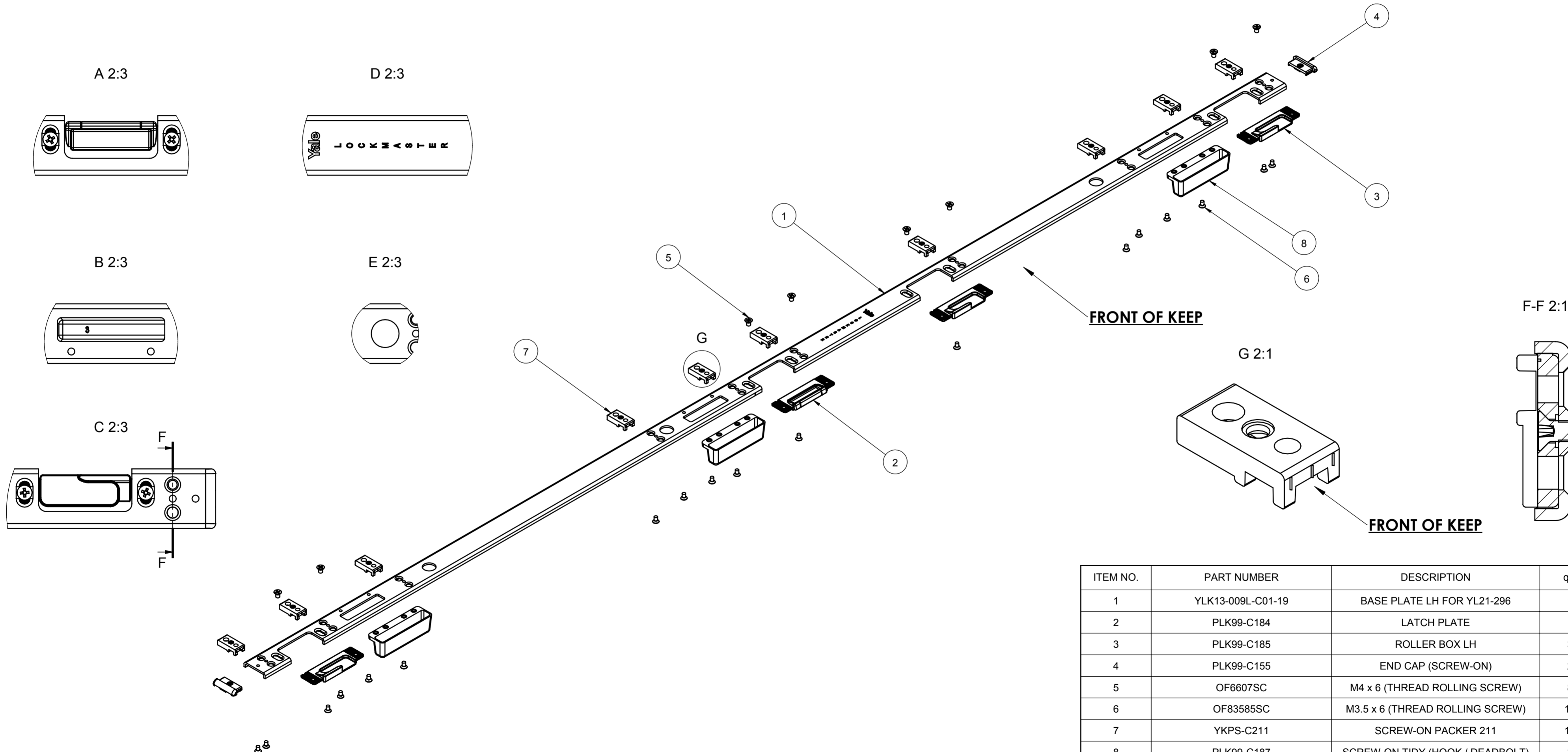
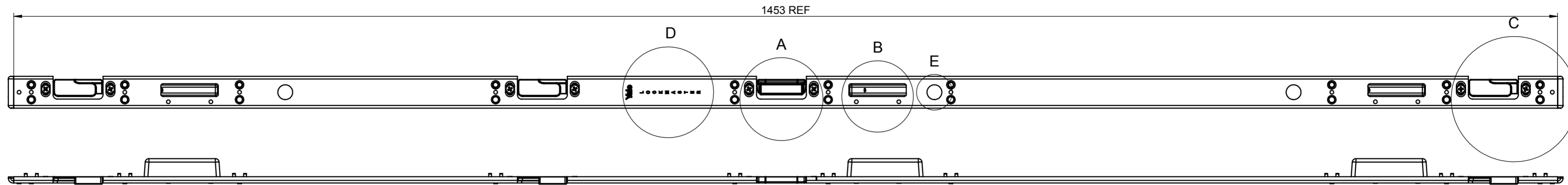

ITEM NO.	PART NUMBER	DESCRIPTION	qty
1	YLK13-009L-C01-19	BASE PLATE LH FOR YL21-296	1
2	PLK99-C184	LATCH PLATE	1
3	PLK99-C185	ROLLER BOX LH	3
4	PLK99-C155	END CAP (SCREW-ON)	2
5	OF6607SC	M4 x 6 (THREAD ROLLING SCREW)	8
6	OF83585SC	M3.5 x 6 (THREAD ROLLING SCREW)	18
7	YKPS-C211	SCREW-ON PACKER 211	10
8	PLK99-C187	SCREW-ON TIDY (HOOK / DEADBOLT)	3

Surface: N/A		Material: N/A		General tolerance: LIN: +/- 0.1mm ANG: +/- 0 Deg 30 Min	
Volume: 139161.93 mm³	Weight: 845.58 gram	Surface area: 163117.51 mm²	Created (YYYY-MM-DD): 2018-03-07	Designed by: PS	Drawn by: PS
ASSA ABLOY ASSA ABLOY UK			Industrial Lock		Scale: 1:3 (A2)
			LH ASSY FOR YL21-296		Projection:
			Alternate ID: YLK13-009L-296-211		Document ID: D000904031-001
			Rev.: 1		